

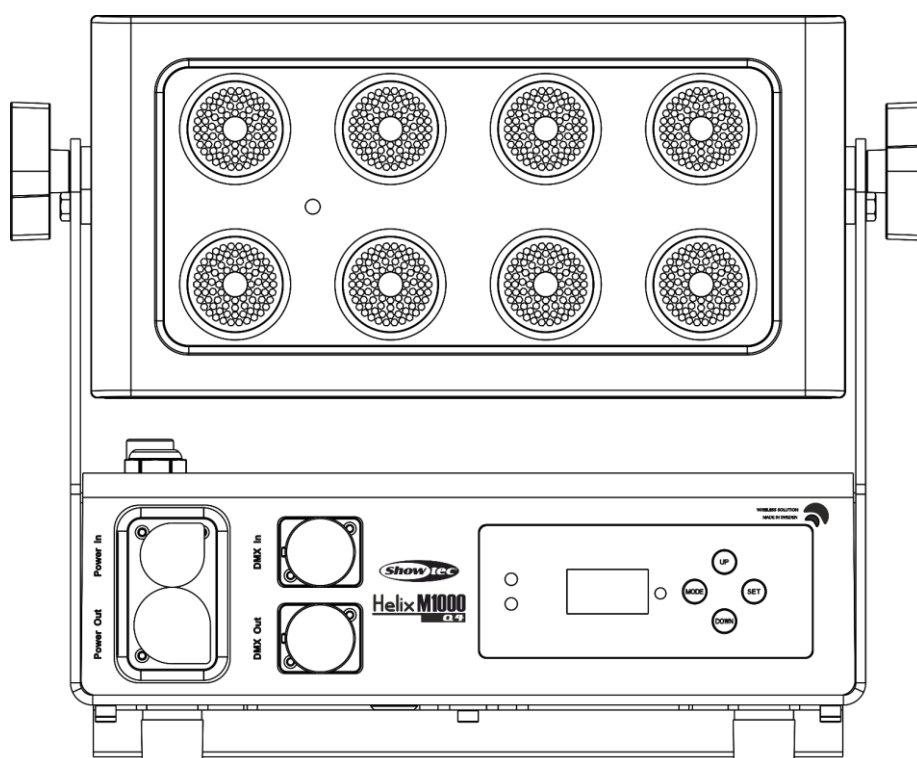

MANUAL



ENGLISH

Helix M1000 Q4 Mobile

V1

Ordercode: 43740

Table of contents

Warning 3

 Safety Instructions 3

 Operating Determinations 5

 Rigging 5

 Connection with the mains 7

 Return Procedure 7

 Claims 7

Description of the device 8

 Features 8

 Overview 9

 Back 9

Installation 10

 Installing the Beamshapers (43745/43746/43747) 10

 Installing the Barndoor (43742) 11

 Installing the Tophat (43741) 12

Set Up and Operation 13

 Control Modes 13

 One Helix (Auto, Built-in Programs) 13

 One Helix (Manual Mode) 13

 Multiple Helixes (Master / Slave Control) 14

 Multiple Helixes (DMX Control) 15

 Multiple Helixes (Wireless DMX Control) 16

 Wireless DMX Connection 16

 Wireless DMX Problems 16

 Connect the Helix to the Wireless DMX Signal Transmitter 16

 Disconnect the Helix from the Wireless DMX Signal Transmitter 16

 Example 1 17

 Example 2 18

 Charging the built-in battery 19

 Fixture Linking 19

 Data Cabling 20

 Control Panel 21

 DMX Control Mode 21

 DMX Addressing 21

 Menu Overview 22

 Main Menu Options 24

 1. DMX Settings 24

 1.1. Address 24

 1.2. Channels 25

 1.3. Signal 25

 1.4. W-DMX Unlock 25

 2. Manual Mode 26

 3. Auto Mode 26

 4. Built-in Programs 26

 4.1. Program 01 27

 4.2. Programs 02-16 27

 5. Master/Slave Mode 27

 6. Settings 28

 6.1. Curves Select 28

 6.2. Dimmer Speed 29

 6.3. DMX Fail 29

 6.4. Working Time 29

 6.5. DMX Sync 30

 6.6. Lock 30

6.7. Calibration30
6.8. Delayed Output.....31
6.9. Factory.....31
7. Information.....31
DMX Channels32
4 Channels32
6 Channels32
10 Channels33

Maintenance35

Troubleshooting35
No Light35
No Response to DMX.....35

Product Specifications37

Dimensions.....38

Warning



**For your own safety, please read this user manual carefully
before your initial start-up!**



Unpacking Instructions

Immediately upon receiving this product, carefully unpack the carton and check the contents to ensure that all parts are present, and have been received in good condition. Notify the dealer immediately and retain packing material for inspection if any parts appear damaged from shipping or the carton itself shows signs of mishandling. Save the carton and all packing materials. In the event that a fixture must be returned to the factory, it is important that the fixture be returned in the original factory box and packing.

Your shipment includes:

- Showtec Helix M1000 Q4 Mobile
- Schuko to True1 pro power cable (1,5 m)
- 1 x safety cable
- 1 x quick-lock bracket
- User manual

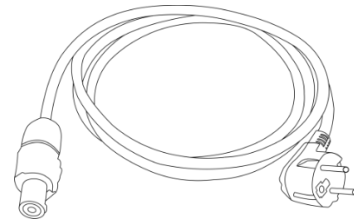
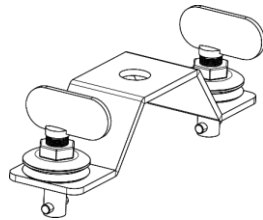
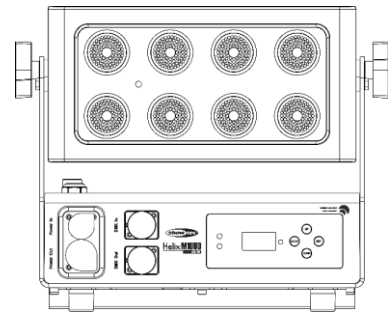

LED Expected Lifespan

LEDs gradually decline in brightness over time. HEAT is the dominant factor that leads to the acceleration of this decline. Packaged in clusters, LEDs exhibit higher operating temperatures than in ideal or singular optimum conditions. For this reason when all color LEDs are used at their fullest intensity, life of the LEDs is significantly reduced. If improving your lifespan expectancy is of a higher priority, place care in providing for lower operational temperatures. This may include climatic-environmental and the reduction of overall projection intensity.



CAUTION!

**Keep this device away from rain and moisture!
Unplug mains lead before opening the housing!**



Safety Instructions

Every person involved with the installation, operation and maintenance of this device has to:

- be qualified
- follow the instructions of this manual



**CAUTION! Be careful with your operations.
With a dangerous voltage you can suffer
a dangerous electric shock when touching the wires!**



Before your initial start-up, please make sure that there is no damage caused by transportation. Should there be any, consult your dealer and do not use the device.

To maintain perfect condition and to ensure a safe operation, it is absolutely necessary for the user to follow the safety instructions and warning notes written in this manual.

Please consider that damages caused by manual modifications to the device are not subject to warranty.

This device contains no user-serviceable parts. Refer servicing to qualified technicians only.

IMPORTANT:

The manufacturer will not accept liability for any resulting damages caused by the non-observance of this manual or any unauthorized modification to the device.

- Never let the power cord come into contact with other cables! Handle the power cord and all connections with the mains with particular caution!
- Never remove warning or informative labels from the unit.
- Never use anything to cover the ground contact.
- Never place any material over the lens.
- Never look directly into the light source.
- Never leave any cables lying around.
- Do not insert objects into air vents.
- Do not connect this device to a dimmer pack.
- Do not switch the device on and off in short intervals, as this would reduce the device's life.
- Do not touch the device's housing bare-handed during its operation. Allow the fixture to cool for at least 5 minutes before handling.
- Do not shake the device. Avoid brute force when installing or operating the device.
- Only operate the fixture after having checked if the housing is firmly closed and all screws are tightly fastened.
- Only operate the device after having familiarized with its functions.
- Avoid flames and do not put close to flammable liquids or gases.
- Always keep case closed while operating.
- Always allow free air space of at least 50 cm around the unit for ventilation.
- Always disconnect power from the mains, when device is not used or before cleaning! Only handle the power cord by the plug. Never pull out the plug by tugging the power cord.
- Make sure that the device is not exposed to extreme heat, moisture or dust.
- Make sure that the available voltage is not higher than stated on the rear panel.
- Make sure that the power cord is never crimped or damaged. Check the device and the power cord from time to time.
- If the lens is obviously damaged, it has to be replaced, so that its functions are not impaired due to cracks or deep scratches.
- If device is dropped or struck, disconnect mains power supply immediately. Have a qualified engineer inspect for safety before operating.
- If the device has been exposed to drastic temperature fluctuation (e.g. after transportation), do not switch it on immediately. The arising condensation water might damage your device. Leave the device switched off until it has reached room temperature.
- If your Showtec device fails to work properly, discontinue use immediately. Pack the unit securely (preferably in the original packing material), and return it to your Showtec dealer for service.
- For adult use only. Device must be installed out of the reach of children. Never leave the unit running unattended.
- Never attempt to bypass the thermostatic switch or fuses.
- The user is responsible for correct positioning and operating of the Helix. The manufacturer will not accept liability for damages caused by the misuse or incorrect installation of this device.
- This device falls under protection class I. Therefore it is essential to connect the yellow/green conductor to earth.
- Repairs, servicing and electric connection must be carried out by a qualified technician.
- **WARRANTY:** Till one year after date of purchase.



CAUTION! Eyedamages!!!
Avoid looking directly into the lightsource!!!
(meant especially for epileptics)!!!



Operating Determinations

- This device is not designed for permanent operation. Consistent operation breaks will ensure that the device will serve you for a long time without defects.
- The minimum distance between light output and the illuminated surface must be bigger than 0,5 meter.
- The maximum ambient temperature $t_a = 40\text{ }^\circ\text{C}$ must never be exceeded.
- In order to eliminate wear and improve the device's lifespan, during periods of non-use, completely disconnect from power source via breaker or by unplugging.
- The relative humidity must not exceed 50 % with an ambient temperature of $40\text{ }^\circ\text{C}$.
- If this device is operated in any other way, than the one described in this manual, the product may suffer damages and the warranty becomes void.
- Any other operation may lead to dangers like short-circuit, burns, electric shock, crash etc.

You endanger your own safety and the safety of others!

Rigging

Please follow the European and national guidelines concerning rigging, trussing and all other safety issues.

Do not attempt the installation yourself!

Always let the installation be carried out by an authorized dealer!

Procedure:

- If the Helix is lowered from the ceiling or high joists, professional trussing systems have to be used.
- Use a clamp to mount the Helix, with the mounting bracket, to the trussing system.
- The Helix must never be fixed swinging freely in the room.
- The installation must always be secured with a safety attachment, e.g. an appropriate safety net or safety cable.
- When rigging, derigging or servicing the Helix, always make sure, that the area below the installation place is blocked and staying in the area is forbidden.

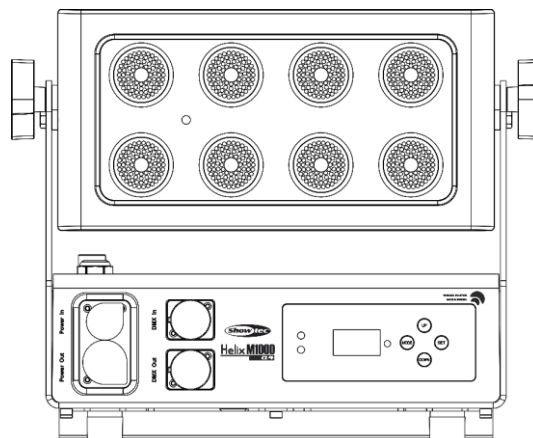

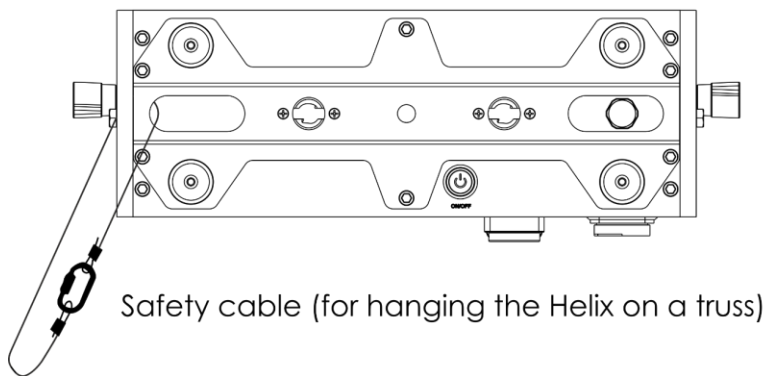
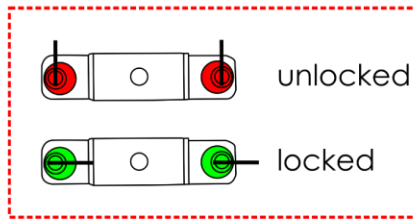
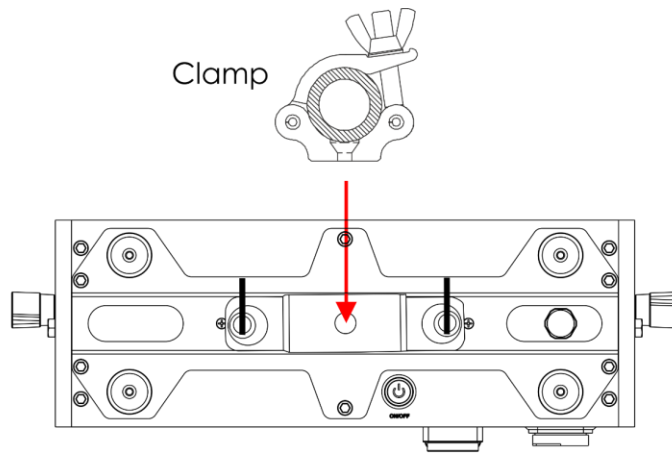

Safety cable (for hanging the Helix on a truss)

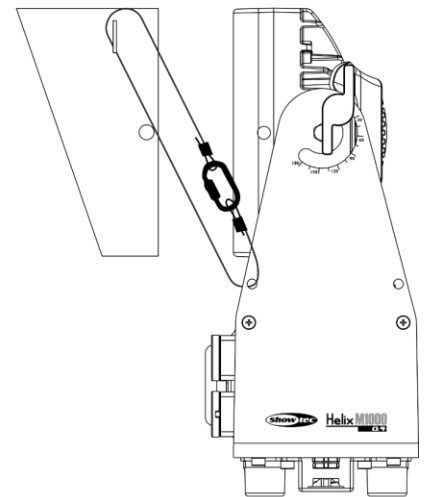

Safety cable (for optional accessories)

The Helix M1000 Q4 Mobile can be placed on a flat stage floor, by means of the included mounting bracket, or be mounted to any kind of truss with a clamp and a quick-lock bracket.

Improper installation can cause serious damage to people and property!

Connection with the mains

Connect the device to the mains with the power-plug.

Always pay attention, that the right color cable is connected to the right place.

International	EU Cable	UK Cable	US Cable	Pin
L	BROWN	RED	YELLOW/COPPER	PHASE
N	BLUE	BLACK	SILVER	NEUTRAL
	YELLOW/GREEN	GREEN	GREEN	PROTECTIVE GROUND

Make sure that the device is always connected properly to the earth!

Improper installation can cause serious damage to people and property!



Return Procedure

Returned merchandise must be sent prepaid and in the original packing, call tags will not be issued. Package must be clearly labeled with a Return Authorization Number (RMA number). Products returned without an RMA number will be refused. Highlite will not accept the returned goods or any responsibility. Call Highlite 0031-455667723 or mail aftersales@highlite.com and request an RMA prior to shipping the fixture. Be prepared to provide the model number, serial number and a brief description of the cause for the return. Be sure to properly pack fixture, any shipping damage resulting from inadequate packaging is the customer's responsibility. Highlite reserves the right to use its own discretion to repair or replace product(s). As a suggestion, proper UPS packing or double-boxing is always a safe method to use.

Note: If you are given an RMA number, please include the following information on a piece of paper inside the box:

- 01) Your name.
- 02) Your address.
- 03) Your phone number.
- 04) A brief description of the symptoms.

Claims

The client has the obligation to check the delivered goods immediately upon delivery for any shortcomings and/or visible defects, or perform this check after our announcement that the goods are at their disposal. Damage incurred in shipping is the responsibility of the shipper; therefore the damage must be reported to the carrier upon receipt of merchandise.

It is the customer's responsibility to notify and submit claims with the shipper in the event that a fixture is damaged due to shipping. Transportation damage has to be reported to us within one day after receipt of the delivery.

Any return shipment has to be made post-paid at all times. Return shipments must be accompanied with a letter defining the reason for return shipment. Non-prepaid return shipments will be refused, unless otherwise agreed in writing.

Complaints against us must be made known in writing or by fax within 10 working days after receipt of the invoice. After this period complaints will not be handled anymore.

Complaints will only then be considered if the client has so far complied with all parts of the agreement, regardless of the agreement of which the obligation is resulting.

Description of the device

Features

The Helix M1000 Q4 Mobile is a versatile RGBW wash fixture with wireless operation. The onboard lithium-ion battery, combined with smart software provide an extended operating time of up to 15 hours, regardless of the intensity of the light output. Wireless DMX and the color programs will help create a solution for each application. A selection of the beamshapers, the barndoor and the tophat add to the versatility of the device. The rating IP65 and sturdy design make this device well equipped for outdoor use.

- Input voltage: 100–240 V AC, 50/60 Hz
- Power consumption: 75 W
- Battery: Lithium-ion
- Battery Voltage: 18,5 V
- Battery Storage: 13 Ah
- Battery life time: 8 h @ Full, 15 h by software
- Charging Cycle: 6 h
- DMX control via standard DMX controller
- Onboard: OLED Graphical display with 4 touch buttons
- Light source: 8 x Prolight Opto RGBW 4-in-1 10 W LEDs
- Light output @ 2 m: 8000 lx
- Refresh rate: 12 kHz
- Dim curves: 4
- DMX modes: 4, 6, 10 channels
- Dimmer: 0–100 %
- Strobe: 0–20 Hz
- Beam angle: 10° (optional 20°, 40°, 15°x60° beamshapers)
- Tilt Angle: 0–180°
- Control modes: Auto, Built-in programs, Manual, Master/Slave, DMX512, W-DMX
- Power connectors: True1 pro power connector IN/OUT
- Data connectors: 5-pin XLR-HD DMX IN/OUT
- Cooling: Passive
- IP rating: IP65
- Working temperature: 0 °C ~ 40 °C
- Housing: Die-cast aluminum
- Wireless DMX (Wireless Solutions)
- Quick-locks for fast rigging and mounting
- Battery management software
- Dimensions: 367 x 126 x 307 mm (LxWxH)
- Weight: 7,5 kg (incl. battery)

Note: Knowledge of DMX is required to fully utilize this unit.

Optional accessories

- [43742](#) – Barndoor for Helix M1000 Q4 Mobile
- [43745](#) – Beamshaper for Helix M1000 Q4 Mobile (20°)
- [43746](#) – Beamshaper for Helix M1000 Q4 Mobile (40°)
- [43747](#) – Beamshaper for Helix M1000 Q4 Mobile (15°x60°)
- [43741](#) – Tophat for Helix M1000 Q4 Mobile
- [50175](#) – W-DMX™ Microbox F-1 G5 Transceiver

Overview

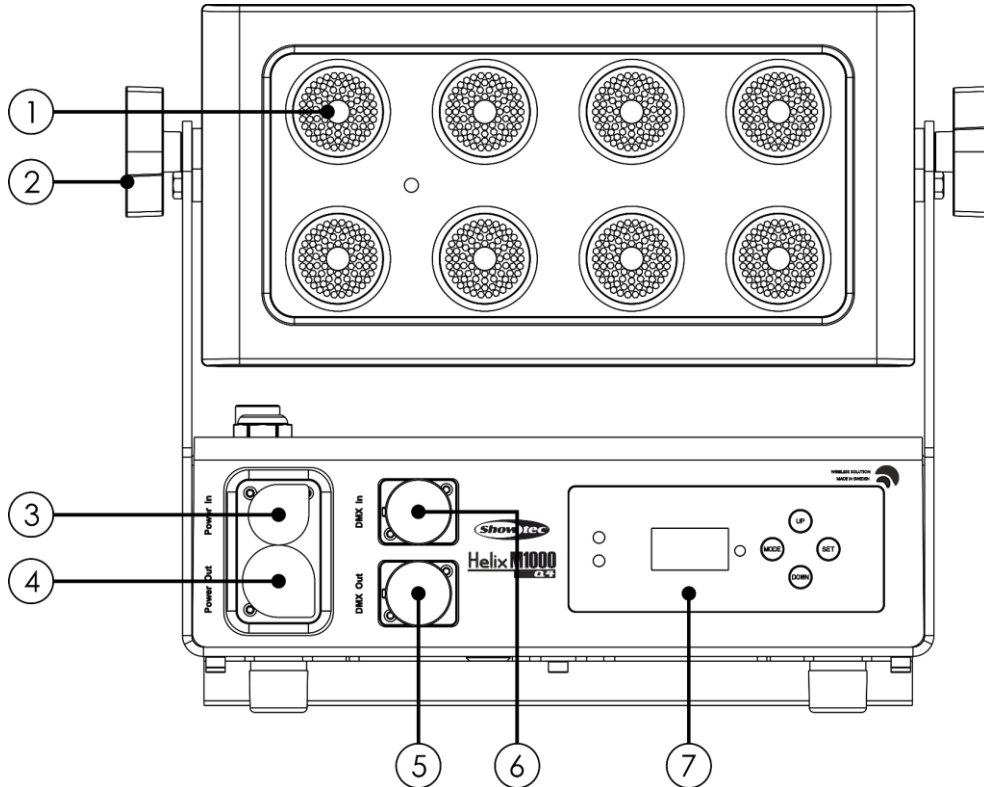

Fig. 01

- 01) 8 x Prolight Opto RGBW 4-in-1 10 W LEDs
- 02) Adjustment screw
- 03) 100–240 V True1 pro power connector IN
- 04) 100–240 V True1 pro power connector OUT
- 05) 5-pin DMX connector OUT
- 06) 5-pin DMX connector IN
- 07) OLED display + control buttons

Back

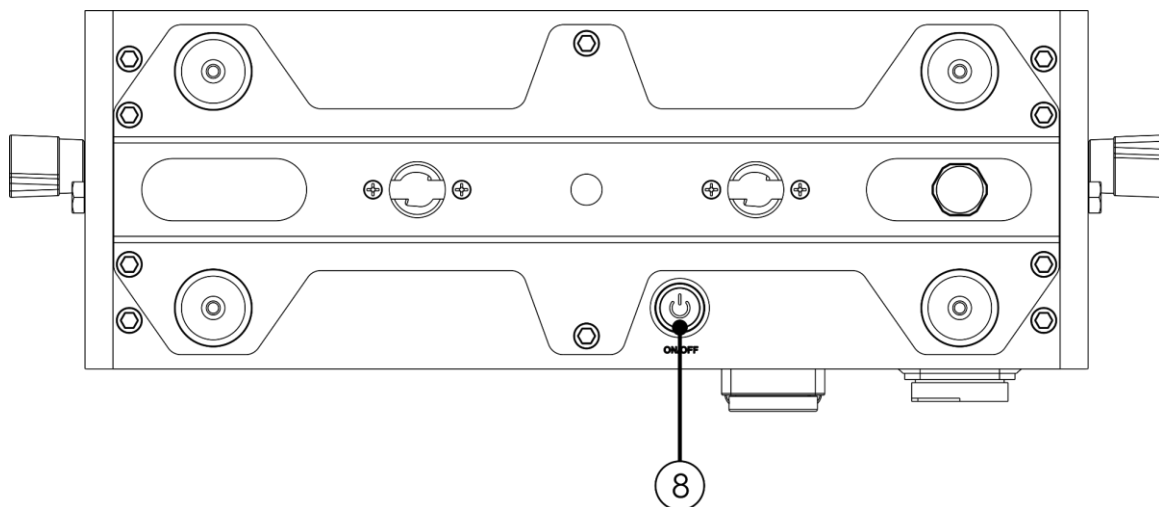

Fig. 02

- 08) Power switch ON/OFF (for battery operation)
Press this switch for the light output to be visible. The current from the built-in battery is responsible for the light output. The True1 pro power cable should be used only when charging the battery.

Installation

Remove all packing materials from the Helix M1000 Q4 Mobile. Check that all foam and plastic padding is removed. Connect all cables.

Do not supply power before the whole system is set up and connected properly.

Always disconnect from electric mains power supply before cleaning or servicing.

Damages caused by non-observance are not subject to warranty.

Installing the Beamshapers (43745/43746/43747)

01) In order to install the Beamshaper, place it on the lens of the Helix. The Beamshaper is equipped with multiple magnets which keep it firmly in position.

02) For extra safety, use a safety cable to connect the Beamshaper to the Helix.

43745 - Beamshaper for Helix M1000 Q4 Mobile (20°)

43746 - Beamshaper for Helix M1000 Q4 Mobile (40°)

43747 - Beamshaper for Helix M1000 Q4 Mobile (15°x60°)

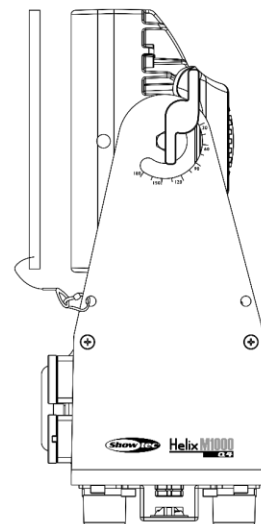
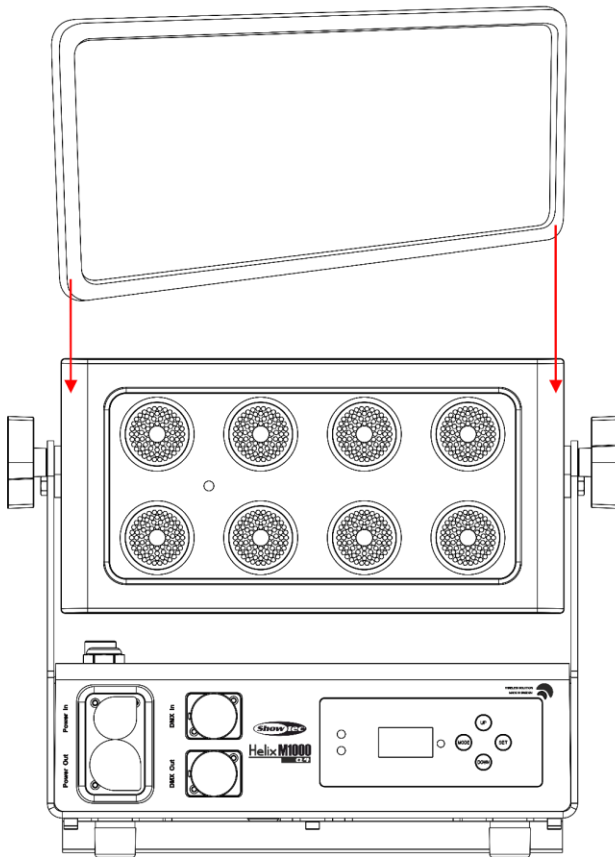

For extra safety, use a safety cable to connect the Beamshaper to the Helix M1000 Q4 Mobile.

Fig. 03

Installing the Barndoor (43742)

01) Pull on the spring-loaded locking screws, on both sides of the Barndoor, to unlock the mechanism.

43742 - Barndoor for Helix M1000 Q4 Mobile

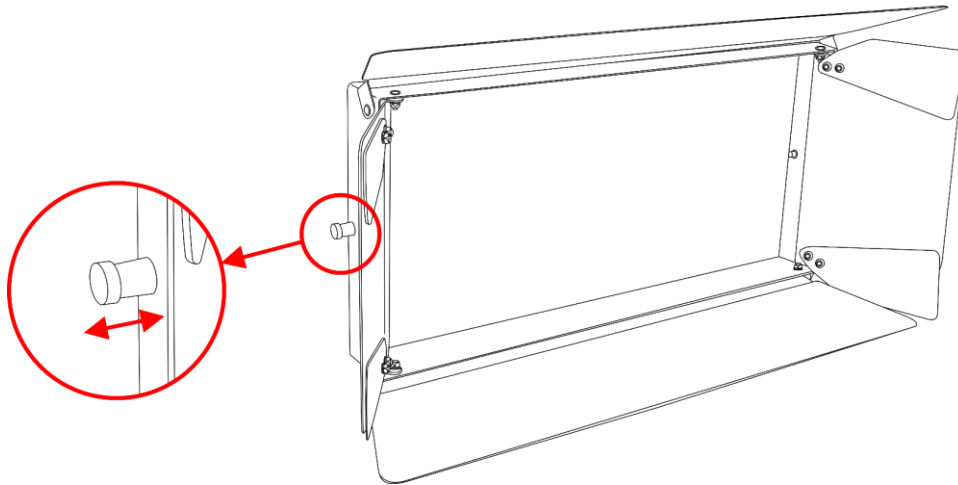

Fig. 04

02) Place the Barndoor on the Helix, to secure the Barndoor's screws in the Helix's mounting holes.

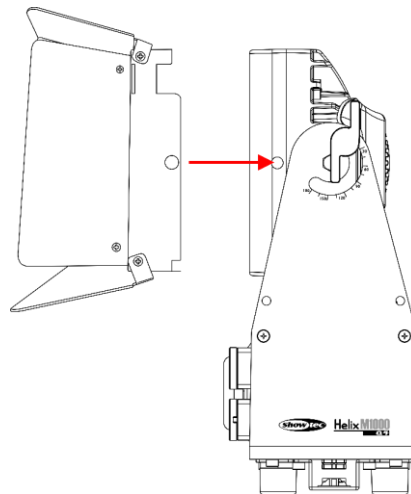
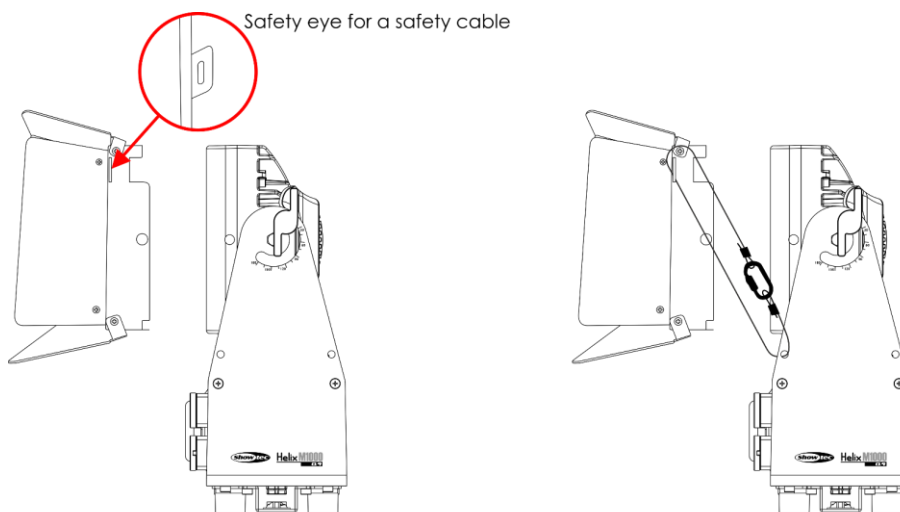

Fig. 05

03) Release both locking screws to lock the Barndoor in position.
04) For extra safety, use a safety cable to connect the Barndoor to the Helix.



For extra safety, use a safety cable to connect the Barndoor to the Helix M1000 Q4 Mobile.

Fig. 06

Installing the Tophat (43741)

01) Pull on the spring-loaded locking screws, on both sides of the Tophat, to unlock the mechanism.

43741 - Tophat for Helix M1000 Q4 Mobile

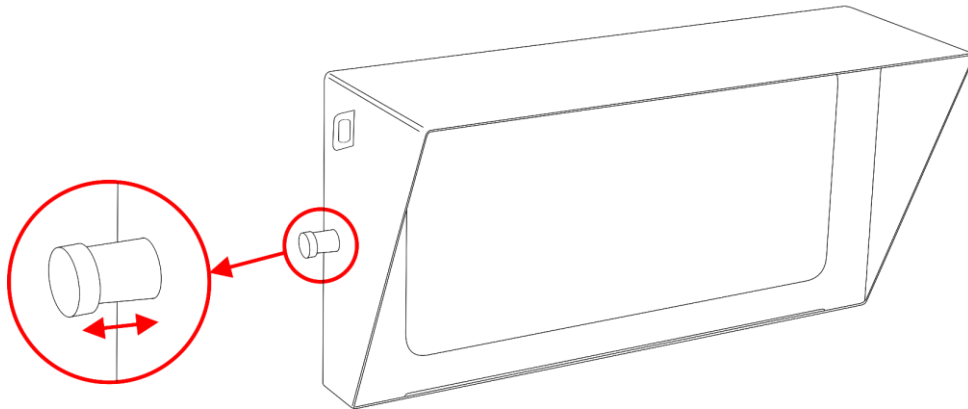

Fig. 07

02) Place the Tophat on the Helix, to secure the Tophat's screws in the Helix's mounting holes.

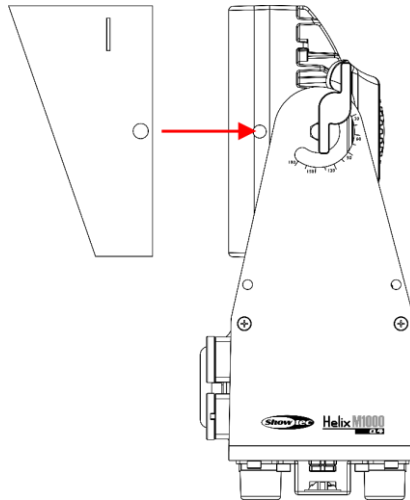
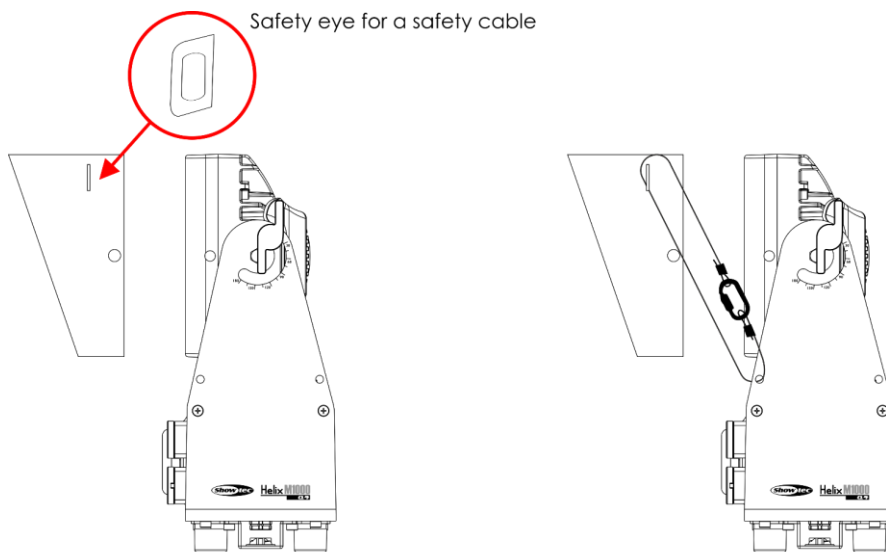

Fig. 08

03) Release both locking screws to lock the Tophat in position.

04) For extra safety, use a safety cable to connect the Tophat to the Helix.



For extra safety, use a safety cable to connect the Tophat to the Helix M1000 Q4 Mobile.

Fig. 09

Set Up and Operation

Follow the directions below, as they pertain to your preferred operation mode.

Before plugging the unit in, always make sure that the power supply matches the product specification voltage. Do not attempt to operate a 120V specification product on 230V power, or vice versa.

Control Modes

There are 6 modes:

- Auto
- Built-in Programs
- Manual
- Master/Slave
- DMX-512 (4CH, 6CH, 10CH)
- Wireless DMX control

One Helix (Auto, Built-in Programs)

- 01) Fasten the effect light onto firm trussing. Leave at least 0,5 meter on all sides for air circulation.
- 02) Always use a safety cable (ordercode 70140 / 70141).
- 03) Plug the end of the electric mains power cord into a proper electric power supply socket.
- 04) **For the light output to be visible, press the power switch ON/OFF (08). The current from the built-in battery is responsible for the light output. The True1 pro power cable should be used only when charging the battery.**
- 05) When the Helix is not connected with a DMX cable, it functions as a stand-alone device.
- 06) Please see pages 26–27 for more information about Auto and Built-in programs.

One Helix (Manual Mode)

- 01) Fasten the effect light onto firm trussing. Leave at least 0,5 meter on all sides for air circulation.
- 02) Always use a safety cable (ordercode 70140 / 70141).
- 03) Plug the end of the electric mains power cord into a proper electric power supply socket.
- 04) **For the light output to be visible, press the power switch ON/OFF (08). The current from the built-in battery is responsible for the light output. The True1 pro power cable should be used only when charging the battery.**
- 05) When the Helix is not connected with a DMX cable, it functions as a stand-alone device.
- 06) Please see page 26 for more information about Manual mode.

Multiple Helixes (Master / Slave Control)

- 01) Fasten the effect light onto firm trussing. Leave at least 0,5 meter on all sides for air circulation.
- 02) Always use a safety cable (ordercode 70140 / 70141).
- 03) Plug the end of the electric mains power cord into a proper electric power supply socket.
- 04) **For the light output to be visible, press the power switch ON/OFF (08). The current from the built-in battery is responsible for the light output. The True1 pro power cable should be used only when charging the battery.**
- 05) Use a 5-pin XLR cable to connect the Helix.

The pins:



- 01) Earth
- 02) Signal (-)
- 03) Signal (+)
- 04) N/C
- 05) N/C

- 06) Link the units as shown in Fig. 10. Connect a DMX signal cable from the first unit's DMX "out" socket to the second unit's "in" socket. Repeat this process to link the second and third units. **Press the power switches ON/OFF (08) on all slave devices, for the light output to be visible.** You can use the same functions on the master device as described on pages 26–27. This means that you can set your desired operation mode on the master device and all slave devices will react the same as the master device.

Multiple Helixes (Master/Slave Set Up)

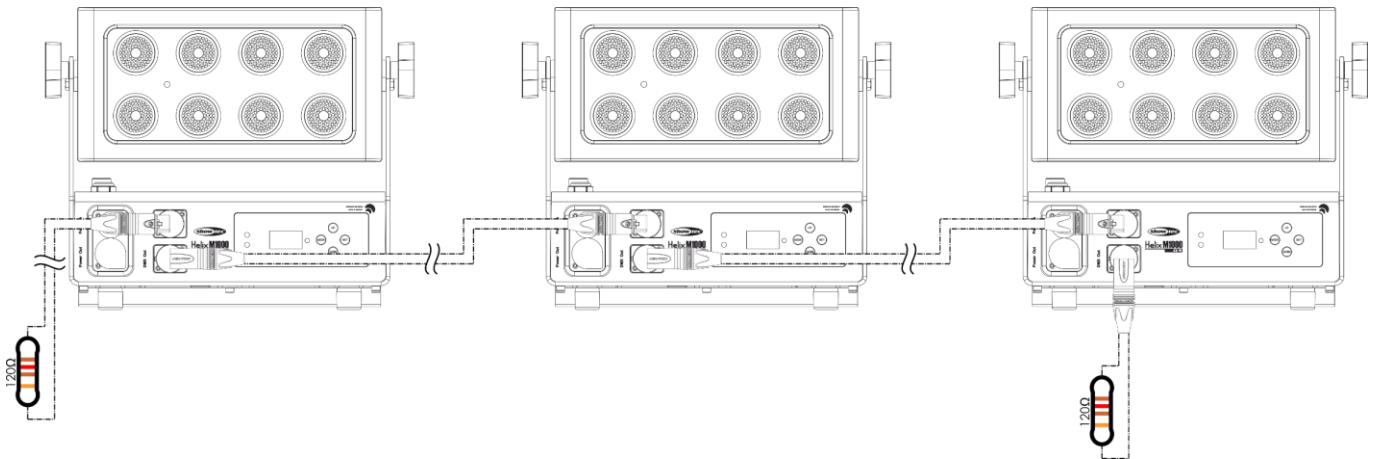

Fig. 10

Multiple Helixes (DMX Control)

- 01) Fasten the effect light onto firm trussing. Leave at least 0,5 meter on all sides for air circulation.
- 02) Always use a safety cable (ordercode 70140 / 70141).
- 03) Plug the end of the electric mains power cord into a proper electric power supply socket.
- 04) Use a 5-pin XLR cable to connect the Helix and other devices.



- 05) Link the units as shown in Fig. 11. Connect a DMX signal cable from the first unit's DMX "out" socket to the second unit's "in" socket. Repeat this process to link the second and third units.
- 06) Supply electric power: Plug electric mains power cords into each unit's True1 pro socket, then plug the other end of the mains power cord into proper electric power supply sockets, starting with the first unit. **Press the power switches ON/OFF (08) on all Helix devices, for the light output to be visible.** Do not supply power before the whole system is set up and connected properly.

Multiple Helixes (DMX Set Up)

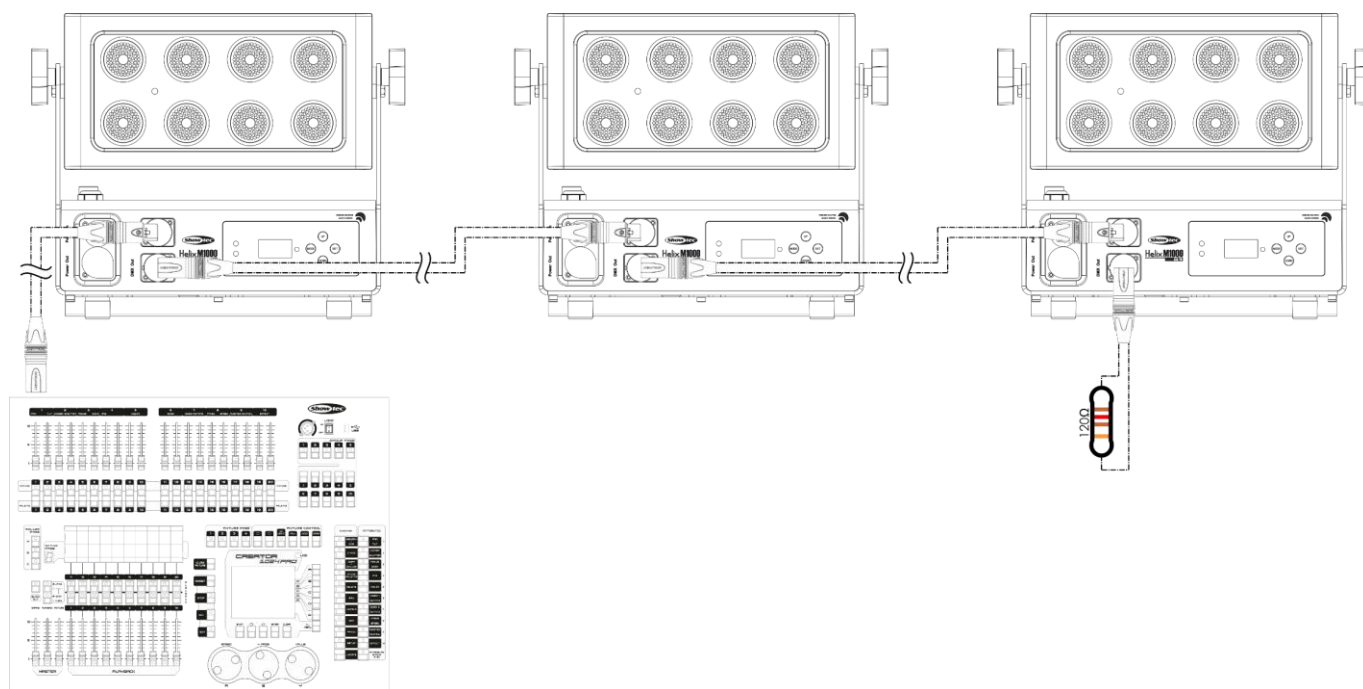

Fig. 11

Note: Link all cables before connecting electric power!

Multiple Helixes (Wireless DMX Control)

You can use the Helix in a wireless DMX setup. Make sure the device is operating in wireless DMX mode, which can be set in the main menu (see page 25 for more information).

Sweden 2.4GHz Wireless Communication Module

Communication distance:	depending on the transmitting power or transmitter module
Test conditions:	W-DMX TRx Transmitter module, 2dBi Antenna, transmitting power 20dBm (100mW)
Range indoor:	60 m (approx. through three concrete walls)
Range outdoor:	250 m

Wireless DMX Connection

The wireless receiving module "Nano G5 Receiver, 2.4GHz", provided by Swedish WIRELESS SOLUTION, only has a 2.4 GHz wireless signal receiving function. In order to establish a wireless connection, please use the (50175) W-DMX MicroBox F-1 G5 Transceiver by WIRELESS SOLUTION. To control the status of the wireless communication, please look at the green LED indicator light on the right-hand side of the display.

Note: When the Helix receives a wireless DMX signal, then this signal will also be present at its 5-pin DMX output (05). However, **the Helix has not been designed to send wireless signals**. Therefore, always connect the Helix devices to each other using a DMX cable.

Wireless DMX Problems

- 01) No signal from the W-DMX transmitter.
The LED indicator will blink quickly.
- 02) Proper connection with the W-DMX transmitter, but no DMX signal is present.
The LED indicator will blink slowly.

When the wireless DMX communication is unhindered and a DMX signal is present, the LED indicator will always be on.



The Helix M1000 Q4 Mobile cannot receive a W-DMX signal and a DMX cable signal at the same time



When the device is in Auto mode or Built-in Programs mode, please ensure that the paired 2.4GHz wireless signal transmitter is OFF.



The Helix M1000 Q4 Mobile is only a W-DMX receiver and never a W-DMX transmitter



Connect the Helix to the Wireless DMX Signal Transmitter

The Helix cannot actively match a random wireless signal transmitter.

In order to create a wireless match, please check the manual of your wireless signal transmitter.

We advise you to use the W-DMX MicroBox F-1 G5 Transceiver (50175) by WIRELESS SOLUTION (Fig. 12).

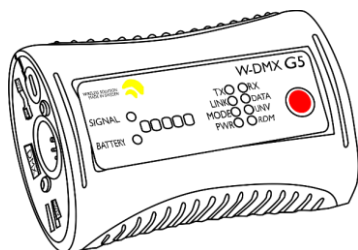

Fig. 12

Disconnect the Helix from the Wireless DMX Signal Transmitter

- 01) Turn off/unlink the W-DMX. In order to do so, deactivate W-DMX (see page 25 for more information).
- 02) Unlink the Helix (see page 25 for more information).
- 03) The Helix will now be disconnected.

Example 1

The Helix cannot send any wireless signals. Therefore, the slave Helix fixtures must always be connected via a DMX signal cable.



The Helix M1000 Q4 Mobile is only a W-DMX receiver and never a W-DMX transmitter



When the Helix operates in DMX or Slave mode, it can receive a wireless DMX signal (CH1–512) and at the same time it can also send a DMX signal, via its DMX output **(05)**, through a DMX cable.

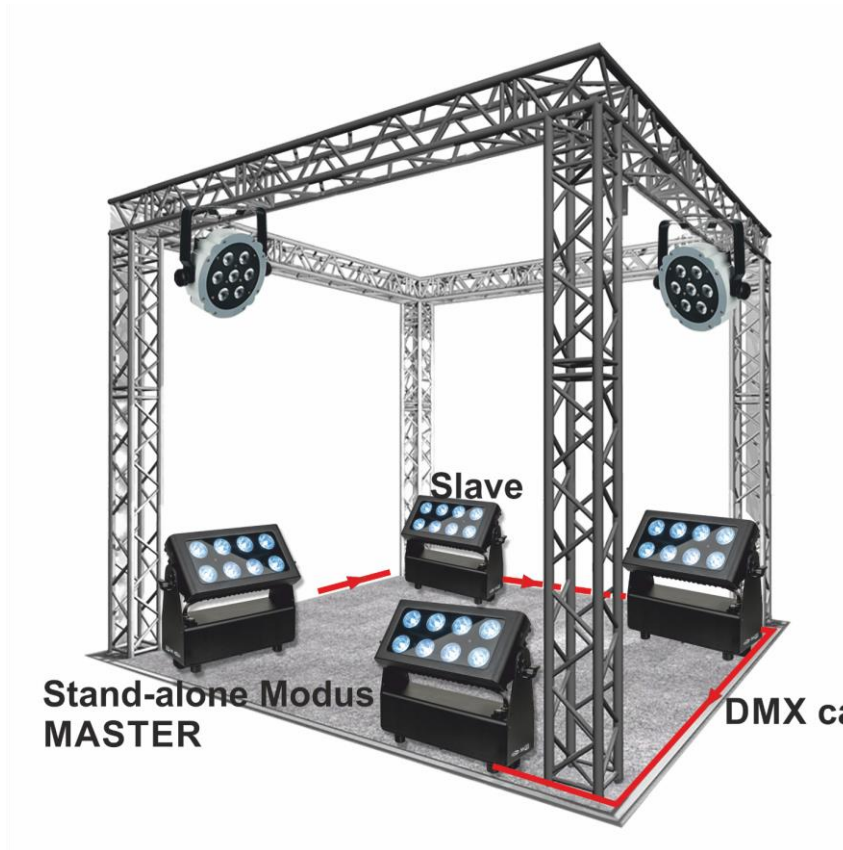

Fig. 13

Example 2

The Showtec Operator Air ([50726](#)) sends out a wireless signal with 512 channels and the Helix picks up this signal.

Connect the Helix to the wireless DMX signal transmitter

The Helix M1000 Q4 Mobile cannot actively search for wireless signal transmitters.

In order to pair the Helix with the wireless signal transmitter, please check the manual of the wireless signal transmitter you use.

It is recommended to use the W-DMX MicroBox F-1 G5 Transceiver ([50175](#)) by WIRELESS SOLUTION.

Disconnect from the Wireless DMX signal transmitter

The Helix can be disconnected from the wireless DMX signal transmitter.

It is possible to deactivate W-DMX in the main menu, see page 25 for more information.

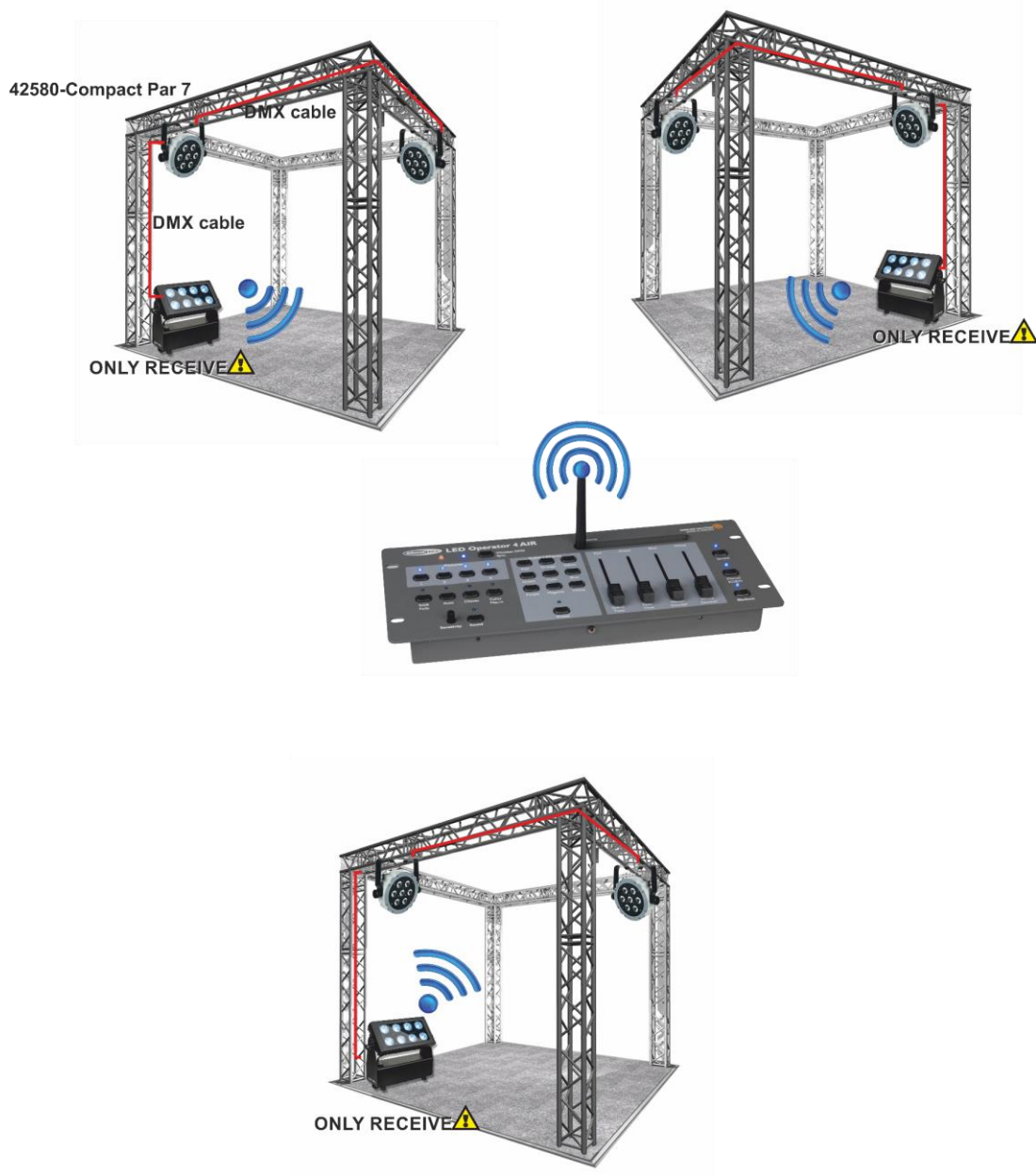

Fig. 14

Charging the built-in battery

The device is equipped with an 18,5 V/13 AH lithium-ion battery.

- 01) Turn off the power switch **(08)**.
- 02) Plug in the True1 pro power cable.
- 03) While the battery is charging, the red LED on the left-hand side of the display will light up.
- 04) When the battery is fully charged, the green LED on the left-hand side of the display will light up.



**You cannot remove the lithium-ion battery and charge it separately.
The battery can only be charged when it is connected to the Helix.**



Important!

- Do not charge the lithium-ion battery for more than 24 hours.
- Please recharge the battery in time, for example when the battery is (almost) depleted. If you do not use the Helix for a long time, please recharge the battery at least once a month, in order to prevent the lithium-ion battery from becoming damaged.
- After a cycle use of 300 times, the battery capacity will be reduced to about 8 AH (70% of the total capacity). Please reduce the charge and discharge times, to extend the battery lifetime. After 300 times of charging and discharging, you need to replace the battery.
- Store in the upright position.

Fixture Linking

You will need a serial data link to run light shows of one or more fixtures using a DMX-512 controller or to run synchronized shows on two or more fixtures set to a master / slave operating mode. The combined number of channels required by all the fixtures on a serial data link determines the number of fixtures the data link can support.

Important:



Fixtures on a serial data link must be daisy chained in one single line. To comply with the EIA-485 standard no more than 30 devices should be connected on one data link. Connecting more than 30 fixtures on one serial data link without the use of a DMX optically isolated splitter may result in deterioration of the digital DMX signal.

Maximum recommended DMX data link distance: 100 meters
Maximum recommended number of fixtures on a DMX data link: 30 fixtures
Maximum recommended number of fixtures on a power link @ 120 V: 20 fixtures
Maximum recommended number of fixtures on a power link @ 230 V: 43 fixtures

Data Cabling

To link fixtures together you must obtain data cables. You can purchase DAP Audio certified DMX cables directly from a dealer/distributor or construct your own cable. If you choose to create your own cable please use data-grade cables that can carry a high quality signal and are less prone to electromagnetic interference.

DAP Audio DMX Data Cables

- DAP Audio Basic microphone cable for allround use. bal. XLR/M 3-pin > XLR/F 3-pin. **Ordercode** FL01150 (1,5 m), FL013 (3 m), FL016 (6 m), FL0110 (10 m), FL0115 (15 m), FL0120 (20 m).
- DAP Audio X-type data cable XLR/M 3-pin > XLR/F 3-pin. **Ordercode** FLX0175 (0,75 m), FLX01150 (1,5 m), FLX013 (3 m), FLX016 (6 m), FLX0110 (10 m).
- DAP Audio cable for the demanding user with exceptional audio-qualities and connector made by Neutrik®. **Ordercode** FL71150 (1,5 m), FL713 (3 m), FL716 (6 m), FL7110 (10 m).
- DAP Audio cable for the demanding user with exceptional audio-qualities and connector made by Neutrik®. **Ordercode** FL7275 (0,75 m), FL72150 (1,5 m), FL723 (3 m), FL726 (6 m), FL7210 (10 m).
- DAP Audio 110 Ohm cable with digital signal transmission. **Ordercode** FL0975 (0,75 m), FL09150 (1,5 m), FL093 (3 m), FL096 (6 m), FL0910 (10 m), FL0915 (15 m), FL0920 (20 m).
- DAP Audio data cable FL08 DMX/AES-EBU, XLR/M 5-pin > XLR/F 5-pin. **Ordercode** FL08150 (1,5 m), FL083 (3 m), FL086 (6 m), FL0810 (10 m), FL0820 (20 m).
- DAP Audio DMX adapter: 5-pin/3-pin. **Ordercode** FLA29.
- DAP Audio DMX adapter: 3-pin/5-pin. **Ordercode** FLA30.
- DAP Audio DMX Terminator 3-pin. **Ordercode** FLA42.
- DAP Audio DMX Terminator 5-pin. **Ordercode** FLA43.

Note: connect the Helix M1000 Q4 Mobile with the dedicated special XLR cables for outdoor use.

[FL83150](#) – Neutrik DMX Cable 5-pin XLR IP65 (1,5 m)

[FL833](#) – Neutrik DMX Cable 5-pin XLR IP65 (3 m)

[FL836](#) – Neutrik DMX Cable 5-pin XLR IP65 (6 m)

[FL8310](#) – Neutrik DMX Cable 5-pin XLR IP65 (10 m)

[FL8320](#) – Neutrik DMX Cable 5-pin XLR IP65 (20 m)

Control Panel

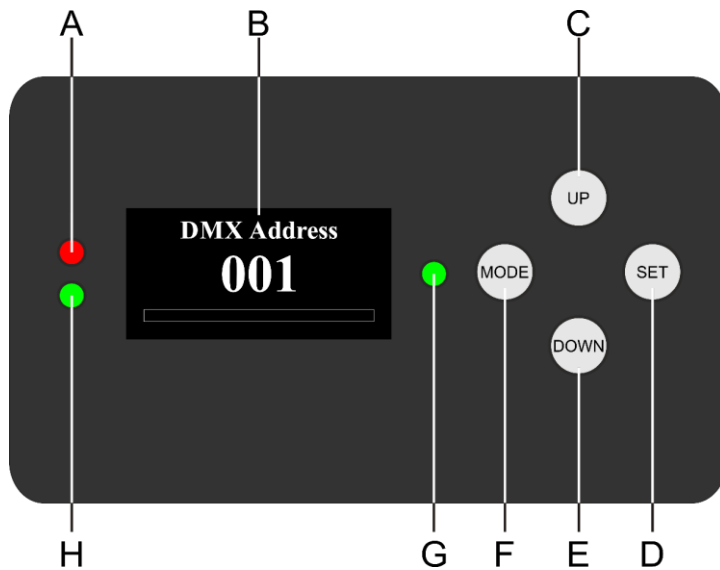

- A) Battery (charging) LED indicator
- B) OLED display
- C) UP button
- D) SET button
- E) DOWN button
- F) MODE button
- G) W-DMX LED indicator
- H) Battery (full) LED indicator

Fig. 15

DMX Control Mode

The fixtures are individually addressed on a data-link and connected to the controller. The fixtures respond to the DMX signal from the controller. (When you select the DMX address and save it, the controller will display the saved DMX address the next time.)

DMX Addressing

The control panel on the back side of the device allows you to assign the DMX fixture address, which is the first channel from which the Helix will respond to the controller.

Please note when you use the controller, the unit has **10** channels.

When using multiple Helixes make sure you set the DMX addresses right.

Therefore, the DMX address of the first Helix should be **1(001)**; the DMX address of the second Helix should be **1+10=11 (011)**; the DMX address of the third Helix should be **11+10=21 (021)**, etc. Please, be sure that you do not have any overlapping channels in order to control each Helix correctly. If two or more Helixes are addressed similarly, they will work similarly.

Controlling:

After having addressed all Helix fixtures, you may now start operating these via your lighting controller.

Note: After switching on, the Helix will automatically detect whether DMX-512 data is received or not. The problem may be:

- The XLR cable from the controller is not connected with the input of the Helix.
- The controller is switched off or defective, the cable or connector is defective, or the signal wires are swapped in the input connector.

Note: It is necessary to insert a XLR termination plug (with 120 Ohm) in the last fixture in order to ensure proper transmission on the DMX data link.

⚠ Display Off after 30 seconds ⚠

When no button is pressed for 30 seconds, the display will turn off.

To unlock the display, you have to **press and hold down the MODE and SET buttons for 3 seconds**. Once you have pressed the buttons, the display will light up.

Menu Overview

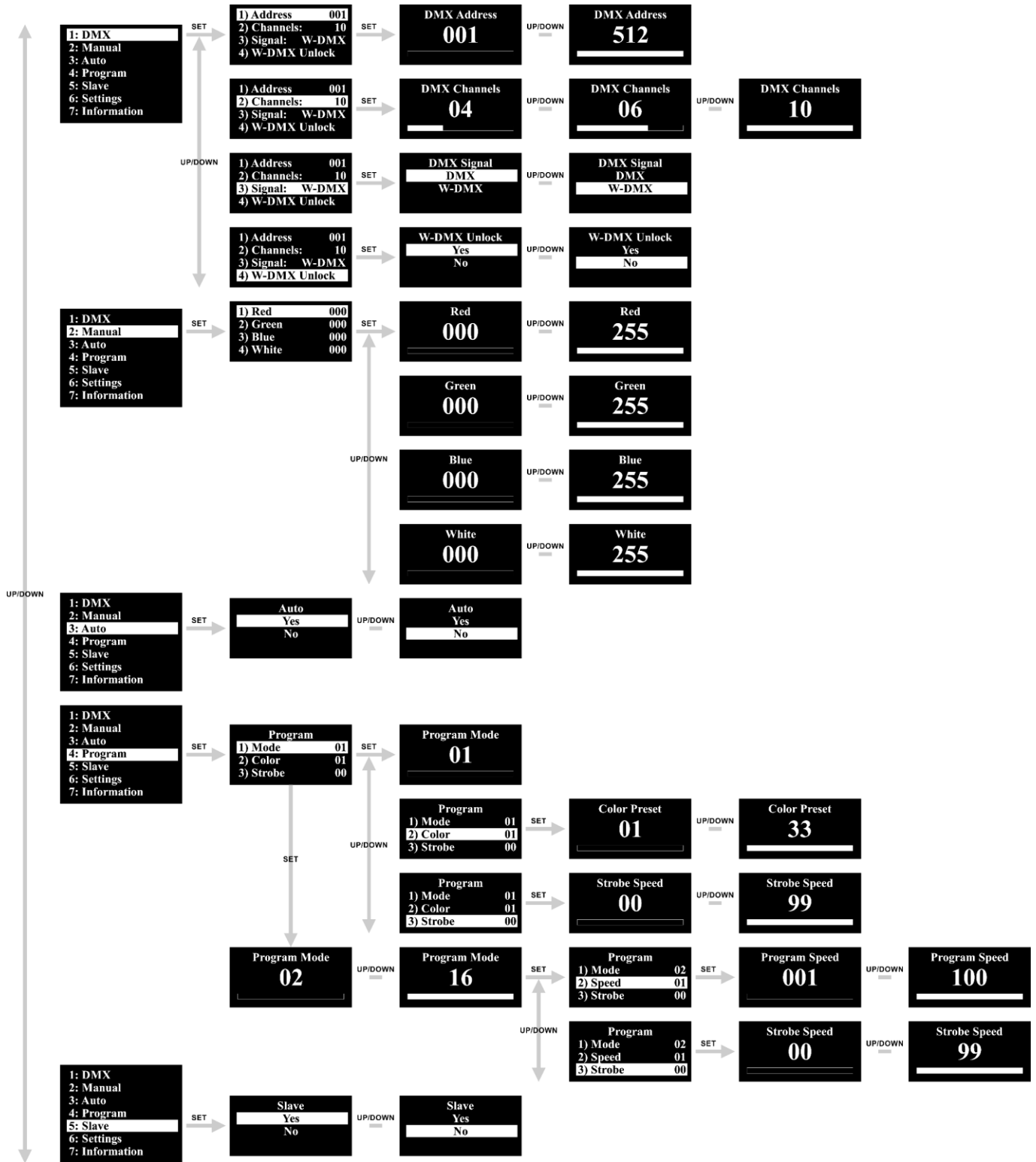

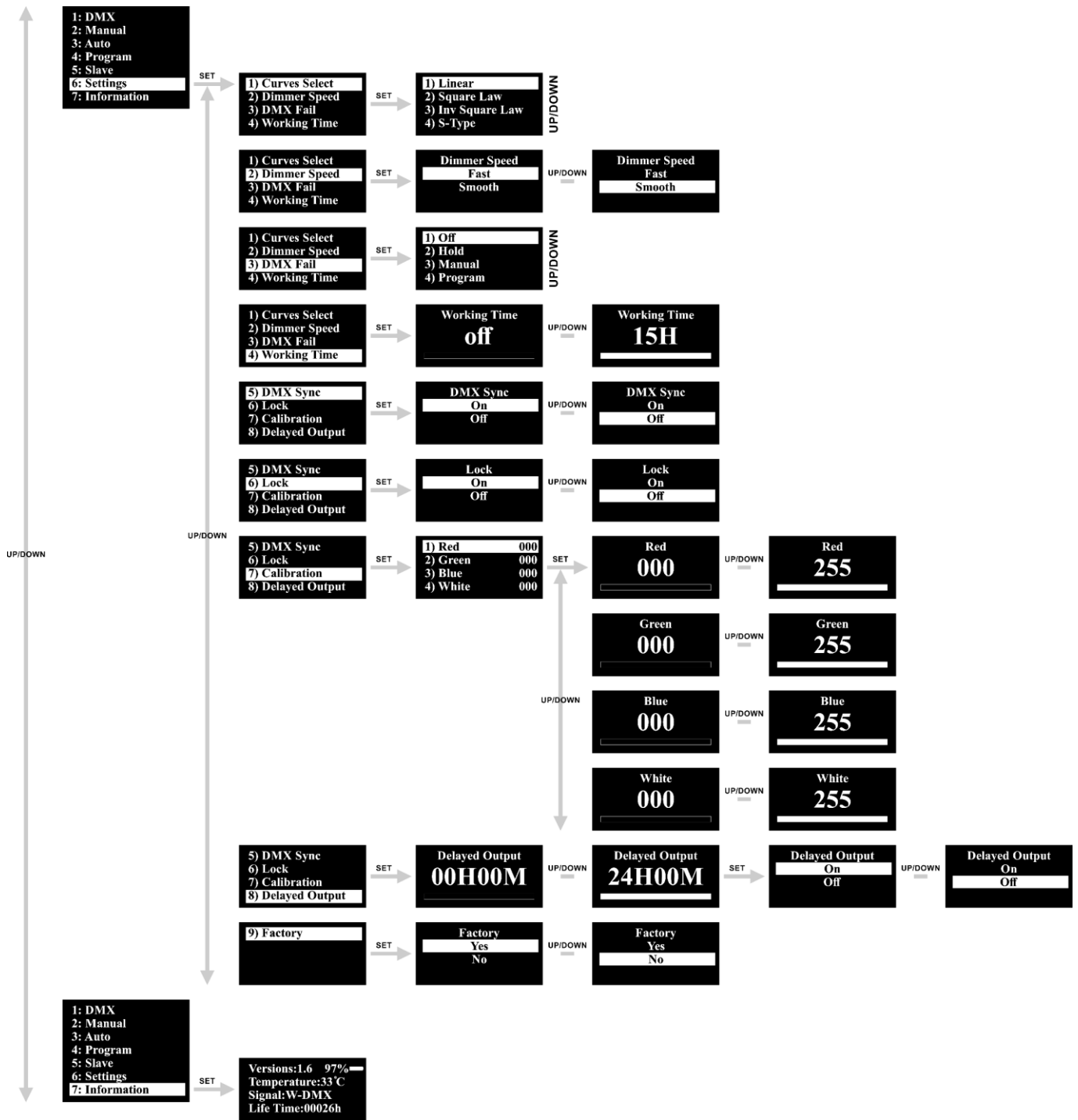

Main Menu Options

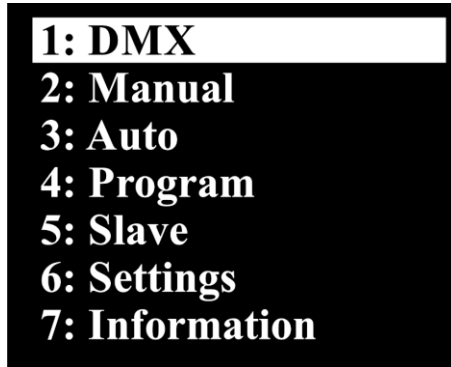

Upon start-up, the display will show the current software version, temperature and the signal type.



1. DMX Settings

With this menu you can set the DMX address, choose the desired DMX mode and activate/deactivate the wireless DMX.

- 01) While in the main menu, press the **UP/DOWN** buttons to choose DMX.
- 02) Press the **SET** button to enter the menu. The display will show:

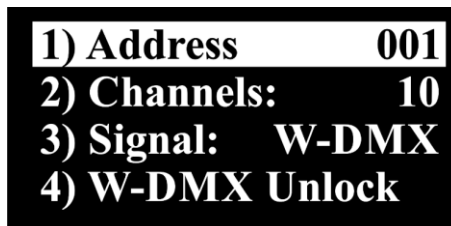

- 03) Press the **UP/DOWN** buttons to select one of the 4 submenus:
 - Address
 - Channels
 - Signal
 - W-DMX unlock

- 04) Press the **SET** button to open the desired submenu.

1.1. Address

With this menu you can set the desired DMX starting address.



- 01) Press the **UP/DOWN** buttons to set the desired DMX address. The adjustment range is 001–512.
- 02) Press the **SET** button to confirm your choice.

1.2. Channels

With this menu you can set the desired DMX channel mode.



01) Press the **UP/DOWN** buttons to set the desired DMX channel mode. Choose one of the 3 options:

- 4 channels
- 6 channels
- 10 channels

02) Press the **SET** button to confirm your choice.

1.3. Signal

With this menu you can set the DMX signal type.



01) Press the **UP/DOWN** buttons to set the desired DMX signal type. Choose one of the 2 options:

- DMX: Conventional DMX
- W-DMX: Wireless DMX

02) Press the **SET** button to confirm your choice.

1.4. W-DMX Unlock

With this menu you can unlock the wireless DMX.

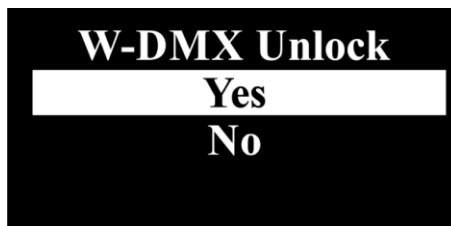

01) Press the **UP/DOWN** buttons to choose YES (to unlock the wireless DMX) or NO (to return to the previous screen).

02) Press the **SET** button to confirm your choice.

2. Manual Mode

With this menu you can manually set the desired color.

- 01) While in the main menu, press the **UP/DOWN** buttons to choose MANUAL.
- 02) Press the **SET** button to enter the menu. The display will show:

1) Red	000
2) Green	000
3) Blue	000
4) White	000

- 03) Press the **UP/DOWN** buttons to choose one of the 4 colors: Red, Green, Blue and White.
- 04) Press the **SET** button to enter the menu.
- 05) Press the **UP/DOWN** buttons to set the intensity of the LEDs. The adjustment range for each color is between 0–255, from dark to brightest.
- 06) Press the **SET** button to save your settings.
- 07) You can combine Red, Green, Blue and White to create an infinite range of colors (0–255).

3. Auto Mode

With this menu you can set Auto mode.

- 01) While in the main menu, press the **UP/DOWN** buttons to choose AUTO.
- 02) Press the **SET** button to enter the menu. The display will show:

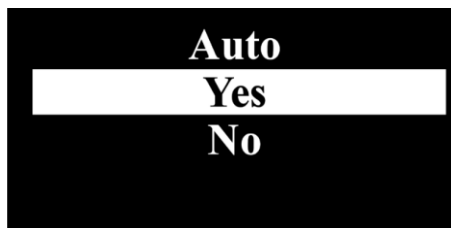

- 03) Press the **UP/DOWN** buttons to choose YES (to start the auto show) or NO (to return to the previous screen).
- 04) Press the **SET** button to confirm your choice.

4. Built-in Programs

With this menu you can set the built-in programs.

- 01) While in the main menu, press the **UP/DOWN** buttons to choose PROGRAM.
- 02) Press the **SET** button to enter the menu. The display will show:

Program	
1) Mode	01
2) Color	01
3) Strobe	00

- 03) Press the **UP/DOWN** buttons to choose MODE and press the **SET** button to enter the menu.
- 04) The display will show:



- 05) Press the **UP/DOWN** buttons to choose one of the 16 built-in programs. Press the **SET** button to confirm your choice.

4.1. Program 01

01) If you have chosen program 01, the display will show:

Program	
1) Mode	01
2) Color	01
3) Strobe	00

02) Press the **UP/DOWN** buttons to choose one of the 2 options:

- COLOR
- STROBE

03) Press the **SET** button to enter the desired menu.

04) If you have chosen COLOR, press the **UP/DOWN** buttons to choose one of the 33 color macros. Press the **SET** button to save your settings.

05) If you have chosen STROBE, press the **UP/DOWN** buttons to set the strobe frequency. The adjustment range is between 0–99, from OFF to high frequency. Press the **SET** button to save your settings.

4.2. Programs 02-16

01) If you have chosen one of the programs 02–16, the display will show:

Program	
1) Mode	02
2) Speed	01
3) Strobe	00

02) Press the **UP/DOWN** buttons to choose one of the 2 options:

- SPEED
- STROBE

03) Press the **SET** button to enter the desired menu.

04) If you have chosen SPEED, press the **UP/DOWN** buttons to set the built-in program's speed. The adjustment range is between 1–100, from slow to fast. Press the **SET** button to save your settings.

05) If you have chosen STROBE, press the **UP/DOWN** buttons to set the strobe frequency. The adjustment range is between 0–99, from OFF to high frequency. Press the **SET** button to save your settings.

5. Master/Slave Mode

With this menu you can set the device as a slave.

01) While in the main menu, press the **UP/DOWN** buttons to choose SLAVE.

02) Press the **SET** button to enter the menu. The display will show:

Slave
Yes
No

03) Press the **UP/DOWN** buttons to choose YES or NO.

04) Press the **SET** button to confirm your choice.

05) If you have chosen YES, the device will be set as a slave and will react the same as the master device.

6. Settings

With this menu you can adjust the device's settings.

- 01) While in the main menu, press the **UP/DOWN** buttons to choose SETTINGS.
- 02) Press the **SET** button to enter the menu. The display will show:



03) Press the **UP/DOWN** buttons to choose one of the 9 submenus:

- CURVES SELECT
- DIMMER SPEED
- DMX FAIL
- WORKING TIME
- DMX SYNC
- LOCK
- CALIBRATION
- DELAYED OUTPUT
- FACTORY

04) Press the **SET** button to enter the desired submenu.

6.1. Curves Select

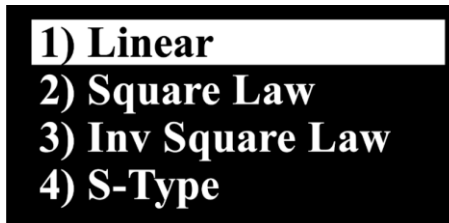

01) Press the **UP/DOWN** buttons to choose one of the 4 dimming curves.

02) Press the **SET** button to confirm your choice.

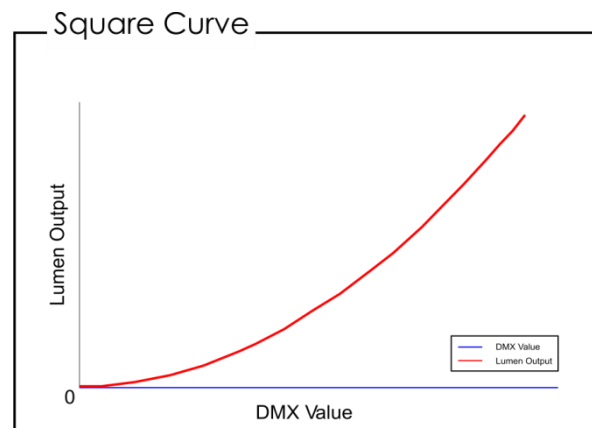
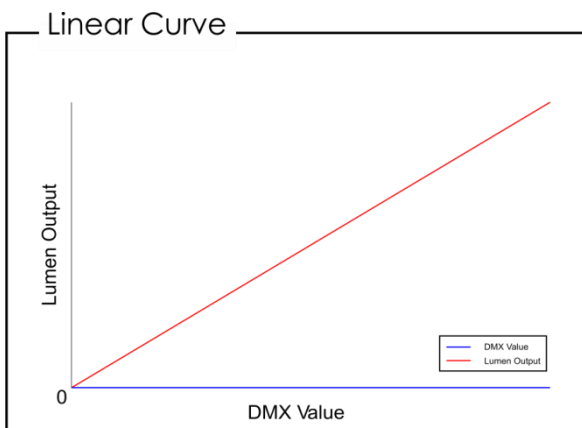

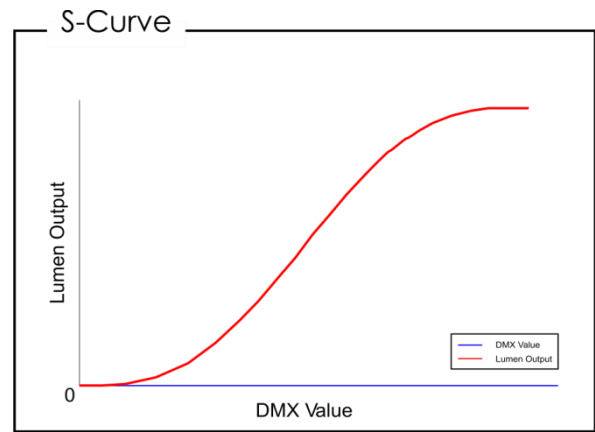
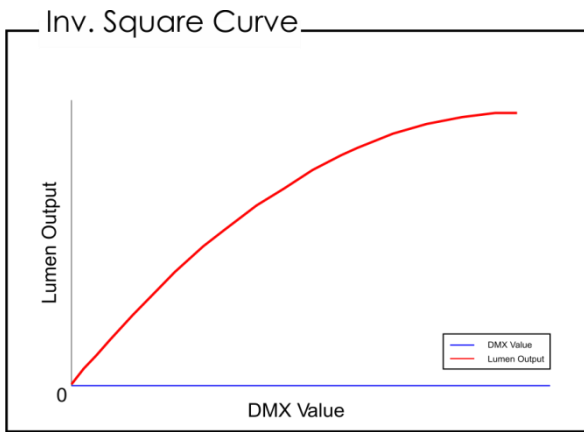

6.2. Dimmer Speed

With this menu you can set the dimmer speed.



- 01) Press the **UP/DOWN** buttons to select FAST or SMOOTH.
- 02) Press the **SET** button to confirm your choice.

6.3. DMX Fail

With this menu you can set the device's behavior in case of a DMX failure.

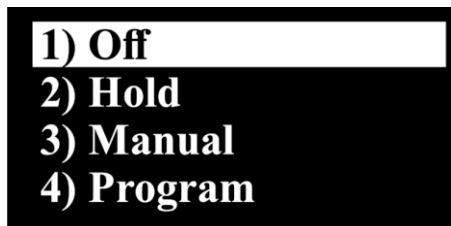

- 01) Press the **UP/DOWN** buttons to select one of the 4 options:
 - OFF: The device will black out the light output
 - HOLD: The device will use last properly received DMX signal, ensuring undisrupted performance
 - MANUAL: The device will switch to Manual mode
 - PROGRAM: The device will run the built-in programs
- 02) Press the **SET** button to confirm your choice.

6.4. Working Time

With this menu you can set the working time of the Helix.

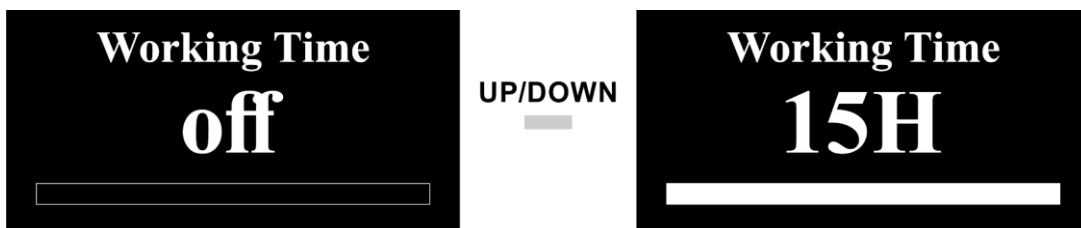

- 01) Press the **UP/DOWN** buttons to select one of the 16 options:
 - OFF: Turns off the working time setting and the device runs at maximum power, until the battery is depleted.
 - 1-15H: Unit working hours, that means limited power operation based on current battery capacity.

Note: After the working time is set, the maximum operating power of the device will be limited, according to the current capacity of the battery, to achieve the set working time. However, if the capacity of the battery is too low, the set time is too long and the working time is not sufficient, then it will run at the minimum power, and the specific time will be shorter than the set time. If the battery capacity is sufficient to perform for the desired amount of time, the device will run at the maximum power, and the working time is uncertain, which may be longer than the set time.

6.5. DMX Sync

With this menu you can set the devices' behavior, while using multiple Helixes.

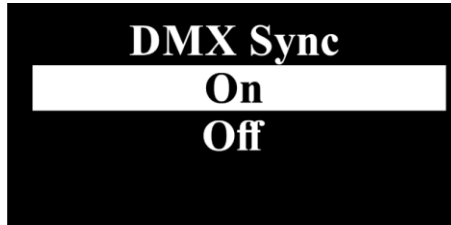

- 01) Press the **UP/DOWN** buttons to select ON (all Helix devices will simultaneously perform the same action, without any delays) or OFF (risk of random delays).
- 02) Press the **SET** button to confirm your choice.

6.6. Lock

With this menu you can set the safety lock, restricting access to the main menu.



- 01) Press the **UP/DOWN** buttons to select one of the 2 options:
 - ON: When no button is pressed within 30 seconds, the device's main menu will be locked. **In order to unlock it, press and hold down the MODE and SET buttons for 3 seconds.**
 - OFF: Safety lock is inactive.
- 02) Press the **SET** button to confirm your choice.

6.7. Calibration

With this menu you can manually calibrate the desired color.



- 01) Press the **UP/DOWN** buttons to choose one of the 4 colors you want to calibrate: Red, Green, Blue and White.
- 02) Press the **SET** button to enter the menu.
- 03) Press the **UP/DOWN** buttons to set the intensity of the LEDs. The adjustment range for each color is between 0–255, from dark to brightest.
- 04) Press the **SET** button to save your settings.
- 05) You can combine Red, Green, Blue and White to create an infinite range of colors (0–255).

6.8. Delayed Output

With this menu you can set the amount of time that needs to pass before the light output becomes activated.



- 01) Press the **UP/DOWN** buttons to select the output delay time between 00H00M–24H00m, in increments of 30 minutes.
- 02) Press the **SET** button to confirm. The display will show:

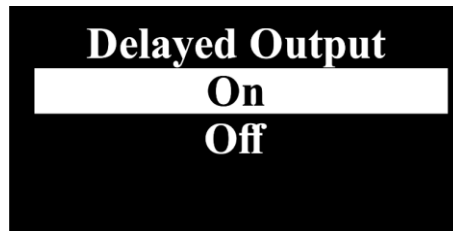

- 03) Press the **UP/DOWN** buttons to select ON or OFF.
- 04) Press the **SET** button to confirm. If you have chosen ON, the device will wait for the determined amount of time and then it will activate its light output.

6.9. Factory

With this menu you can restore the default factory settings.



- 01) Press the **UP/DOWN** buttons to select YES or NO.
- 02) Press the **SET** button to confirm your choice.

7. Information

With this menu you can view the device's current software version, temperature, total lifetime and the type of DMX signal.

- 01) While in the main menu, press the **UP/DOWN** buttons to choose INFORMATION.
- 02) Press the **SET** button to enter the menu. The display will show:

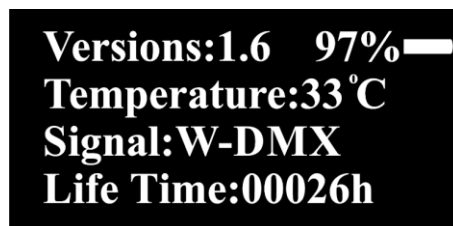

- 03) Press the **UP/DOWN** buttons to toggle through the screens.

DMX Channels

4 Channels

Channel 1 – Red

0–255 Gradual adjustment Red, from dark to brightest

Channel 2 – Green

0–255 Gradual adjustment Green, from dark to brightest

Channel 3 – Blue

0–255 Gradual adjustment Blue, from dark to brightest

Channel 4 – White

0–255 Gradual adjustment White, from dark to brightest

6 Channels

Channel 1 – Dimmer

0–255 Dimmer intensity, from dark to brightest

Channel 2 – Strobe CH1 must be open; CH3–6 must be open

0–10 Not functional

11–128 Random Strobe flash frequency, from OFF to highest frequency

129–255 Strobe flash frequency, from OFF to highest frequency

Channel 3 – Red CH1 must be open

0–255 Gradual adjustment Red, from dark to brightest

Channel 4 – Green CH1 must be open

0–255 Gradual adjustment Green, from dark to brightest

Channel 5 – Blue CH1 must be open

0–255 Gradual adjustment Blue, from dark to brightest

Channel 6 – White CH1 must be open

0–255 Gradual adjustment White, from dark to brightest

10 Channels

Channel 1 – Dimmer

0–255 Dimmer intensity, from dark to brightest

Channel 2 – Strobe CH1 must be open; CH3 or CH4 or CH7–10 must be open

0–10 Not functional

11–128 Random Strobe flash frequency, from OFF to highest frequency

129–255 Strobe flash frequency, from OFF to highest frequency

Channel 3 – Color macros CH1 must be open; CH4 must be closed

0–7 Not functional

8–13 Color1(R255 G000 B000 W000)

14–20 Color2(R255 G000 B000 W100)

21–27 Color3(R255 G000 B000 W200)

28–34 Color4(R255 G050 B000 W000)

35–41 Color5(R255 G150 B000 W000)

42–48 Color6(R255 G255 B000 W000)

49–55 Color7(R255 G255 B000 W075)

56–62 Color8(R000 G255 B000 W255)

63–69 Color9(R000 G255 B000 W150)

70–76 Color10(R000 G255 B000 W050)

77–83 Color11(R000 G255 B000 W000)

84–90 Color12(R000 G255 B050 W000)

91–97 Color13(R000 G255 B150 W000)

98–104 Color14(R000 G255 B255 W000)

105–111 Color15(R000 G255 B255 W075)

112–118 Color16(R000 G255 B255 W150)

119–125 Color17(R000 G100 B255 W255)

126–132 Color18(R000 G000 B255 W100)

133–139 Color19(R000 G000 B255 W050)

140–146 Color20(R000 G000 B255 W000)

147–153 Color21(R075 G000 B255 W000)

154–160 Color22(R160 G000 B255 W000)

161–167 Color23(R255 G000 B255 W000)

168–174 Color24(R255 G000 B175 W000)

175–181 Color25(R255 G000 B100 W000)

182–188 Color26(R255 G000 B100 W050)

189–195 Color27(R255 G000 B025 W050)

196–202 Color28(R255 G000 B025 W025)

203–209 Color29(R255 G000 B025 W000)

210–216 Color30(R000 G000 B000 W255)

217–223 Color31(R075 G075 B000 W255)

224–230 Color32(R000 G000 B100 W255)

231–255 Color33(R255 G255 B255 W255)

Channel 4 – Color switch/Color flow ⚠ CH1 must be open ⚠

0–15	Not functional
16–31	Color switch 1
32–47	Color switch 2
48–63	Color switch 3
64–79	Color switch 4
80–95	Color switch 5
96–111	Color switch 6
112–127	Color switch 7
128–143	Color switch 8
144–159	Color flow 1
160–175	Color flow 2
176–191	Color flow 3
192–207	Color flow 4
208–223	Color flow 5
224–239	Color flow 6
240–255	Color flow 7

Channel 5 – Built-in program speed ⚠ CH4 must be set between 16–255 ⚠

0–255	Gradual speed adjustment, from fast to slow
-------	---------------------------------------------

Channel 6 – Color switch/Color flow ⚠ CH1 must be open ⚠

0–36	No functional
37–73	Dimmer Fast
74–110	Dimmer Slow
111–147	Linear curve
148–184	Square curve
185–221	Inv. Square curve
222–255	S-type curve

Channel 7 – Red ⚠ CH1 must be open; CH3–4 must be closed ⚠

0–255	Gradual adjustment Red, from dark to brightest
-------	------------------------------------------------

Channel 8 – Green ⚠ CH1 must be open; CH3–4 must be closed ⚠

0–255	Gradual adjustment Green, from dark to brightest
-------	--------------------------------------------------

Channel 9 – Blue ⚠ CH1 must be open; CH3–4 must be closed ⚠

0–255	Gradual adjustment Blue, from dark to brightest
-------	-------------------------------------------------

Channel 10 – White ⚠ CH1 must be open; CH3–4 must be closed ⚠

0–255	Gradual adjustment White, from dark to brightest
-------	--------------------------------------------------

Maintenance

The Showtec Helix M1000 Q4 Mobile requires almost no maintenance. However, you should keep the unit clean. Otherwise, the fixture's light output will be significantly reduced. Disconnect the mains power supply and then wipe the cover with a damp cloth. Wipe the front glass panel clean with glass cleaner and a soft cloth. Do not use alcohol or solvents. The front glass panel will require weekly cleaning, as smoke-fluid tends to build up residues, reducing the light output very quickly. Do not immerse in liquid. Keep connections clean. Disconnect electric power, and then wipe the DMX and audio connections with a damp cloth. Make sure connections are thoroughly dry before linking equipment or supplying electric power.

The operator has to make sure that safety-related and machine-technical installations are to be inspected by an expert after every year in the course of an acceptance test.

The operator has to make sure that safety-related and machine-technical installations are to be inspected by a skilled person once a year.

The following points have to be considered during the inspection:

- 01) All screws used for installing the device or parts of the device have to be tightly connected and must not be corroded.
- 02) There may not be any deformations on housings, fixations and installation spots.
- 03) Mechanically moving parts like axles, eyes and others may not show any traces of wearing.
- 04) The electric power supply cables must not show any damages or material fatigue.

Troubleshooting

No Light

If the light effect does not operate properly, refer servicing to a technician.

Suspect three potential problem areas as: the power supply, the LEDs, the internal fuse.

- 01) Power supply. Check if the unit is plugged into an appropriate power supply.
- 02) The LEDs. Return the Helix to your Showtec dealer.
- 03) The internal fuse. Return the Helix to your Showtec dealer.
- 04) If all appears to be O.K., plug the unit in again.
- 05) If you are unable to determine the cause of the problem, do not open the Helix, as this may damage the unit and the warranty will become void.
- 06) Return the device to your Showtec dealer.

No Response to DMX

- 01) Check the DMX setting. Make sure that DMX addresses are correct.
- 02) Check the DMX cable: Unplug the unit; change the DMX cable; then reconnect to electrical power. Try your DMX control again.
- 03) Determine whether the controller or light effect is at fault. Does the controller operate properly with other DMX products? If not, take the controller in for repair. If so, take the DMX cable and the light effect to a qualified technician.

Problem	Probable cause(s)	Remedy
One or more fixtures do not function at all	No power to the fixture	<ul style="list-style-type: none"> • Check if power is switched on and cables are plugged in
	Internal fuse blown	<ul style="list-style-type: none"> • Return the device to your Showtec dealer
Fixtures reset correctly, but all respond erratically or not at all to the controller	The controller is not connected	<ul style="list-style-type: none"> • Connect controller
	5-pin XLR Out of the controller does not match XLR In of the first fixture on the link (i.e. signal is reversed)	<ul style="list-style-type: none"> • Install a phase reversing cable between the controller and the first fixture on the link
Fixtures reset correctly, but some respond erratically or not at all to the controller	Poor data quality	<ul style="list-style-type: none"> • Check data quality. If much lower than 100 percent, the problem may be a bad data link connection, poor quality or broken cables, missing termination plug, or a defective fixture disturbing the link
	Bad data link connection	<ul style="list-style-type: none"> • Inspect connections and cables. Correct poor connections. Repair or replace damaged cables
	Data link not terminated with 120 Ohm termination plug	<ul style="list-style-type: none"> • Insert termination plug in output jack of the last fixture on the link
	Incorrect addressing of the fixtures	<ul style="list-style-type: none"> • Check address setting
	One of the fixtures is defective and disturbs data transmission on the link	<ul style="list-style-type: none"> • Bypass one fixture at a time until normal operation is regained: unplug both connectors and connect them directly together • Have the defective fixture serviced by a qualified technician
	5-pin XLR Out on the fixtures does not match (pins 2 and 3 reversed)	<ul style="list-style-type: none"> • Install a phase-reversing cable between the fixtures or swap pin 2 and 3 in the fixture, that behaves erratically
No light or LEDs cuts out intermittently	Fixture is too hot	<ul style="list-style-type: none"> • Allow the fixture to cool down • Make sure air vents are not blocked • Turn up the air conditioning
	LEDs damaged	<ul style="list-style-type: none"> • Disconnect fixture and return to your dealer
	The power supply settings do not match local AC voltage and frequency	<ul style="list-style-type: none"> • Disconnect fixture. Check settings and correct if necessary

Product Specifications

Model:	Showtec Helix M1000 Q4 Mobile
Input voltage:	100–240V AC, 50/60 Hz
Power consumption:	75 W
DMX linking:	30pcs
Dimensions:	367 x 126 x 307 mm (LxWxH)
Weight:	7,5 kg (incl. battery)
Operating and Programming:	
Signal pin OUT:	Pin 1 (earth), pin 2 (-), pin 3 (+), pin 4 (N/C), pin 5 (N/C)
DMX mode:	4, 6, 10 channels
Signal input:	5-pin XLR-HD IN
Signal output:	5-pin XLR-HD OUT
Electro-mechanical effects:	
Light source:	8 x Prolight Opto RGBW 4-in-1 10 W LEDs
Light output @ 2 m:	8000 lx
Refresh rate:	12 kHz
Beam angle:	10° (optional 20°, 40°, 15°x60° beamshapers)
Dimmer:	0–100 %
Strobe:	0–20 Hz
Dim curves:	4
Tilt angle:	0–180°
Battery:	Lithium-ion
Battery voltage:	18,5 V
Battery storage:	13 Ah
Battery life time:	8 h @ Full, 15 h by software
Charging cycle:	6 h
Rigging:	Quick-locks for fast rigging and mounting
Wireless DMX:	Wireless Solutions
IP rating:	IP65
DMX control:	via standard DMX controller
Onboard:	OLED Graphical display with 4 touch buttons
Control modes:	Auto, Built-in programs, Manual, Master/Slave, DMX512, W-DMX
Housing:	Die-cast aluminum
Connections:	True1 pro power connector & data connector
Cooling:	Passive
Working temperature:	0 °C ~ 40 °C
Max. ambient temperature t_a : 40 °C	Max. housing temperature t_B : 70 °C
Minimum distance:	
Minimum distance from flammable surfaces:	0,5 m
Minimum distance to lighted object:	1 m

Design and product specifications are subject to change without prior notice.



Website: www.Showtec.info
 Email: service@highlite.com

Dimensions

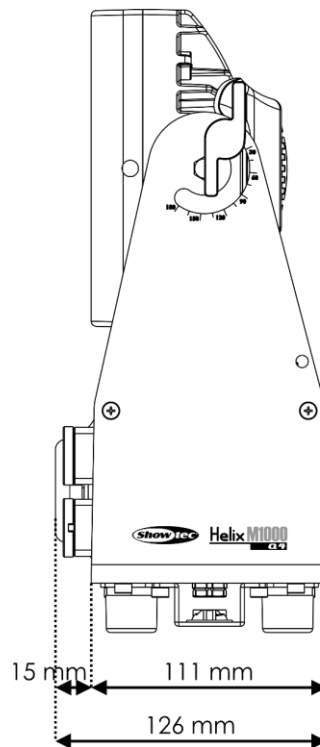
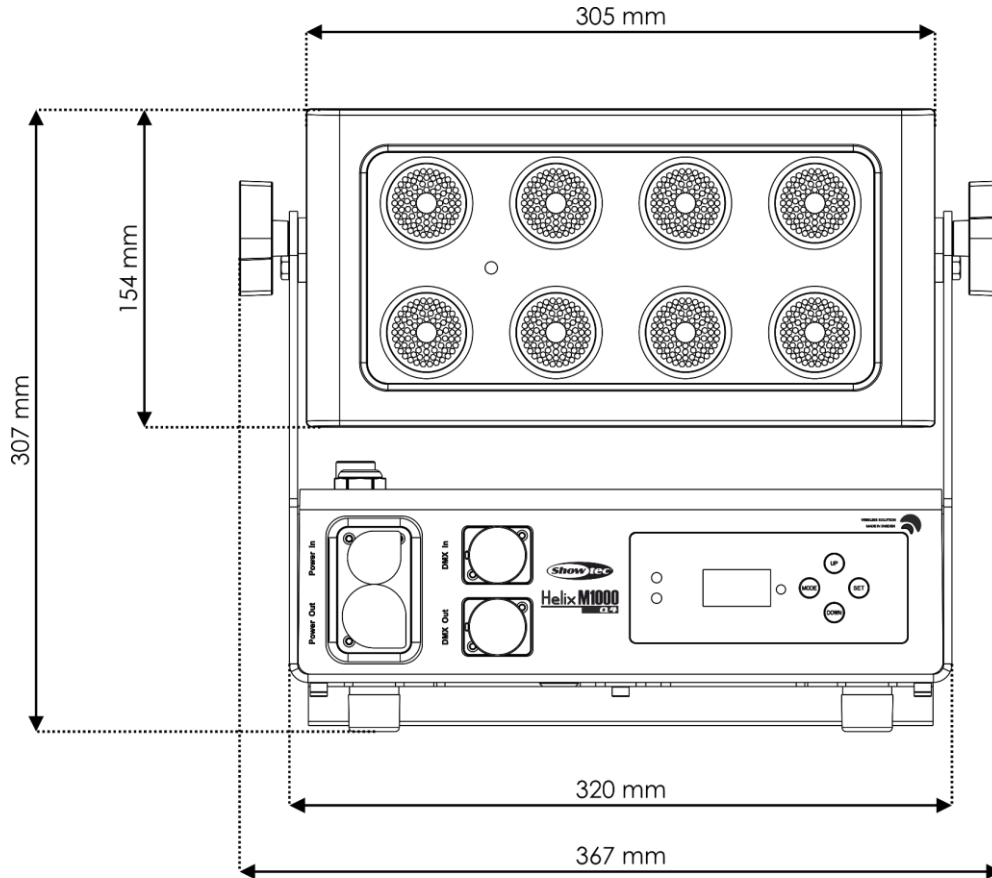



©2020 Showtec