

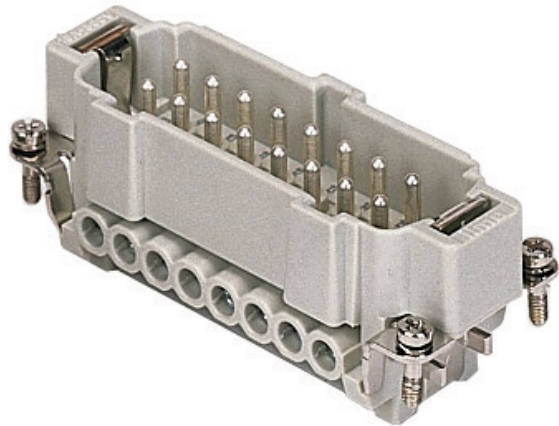

Part number

**CNEM 16 T**



male insert, CNE series, screw terminal connection, 16 poles + PE, 16 A 500 V 6 kV 3, size "77.27", with plate

Product description	
<b>Product type</b>	Insert
<b>Series</b>	CNE
<b>Connection type</b>	screw terminal connection
<b>Gender</b>	male
<b>N. of poles</b>	16 poles + 
<b>Size</b>	size "77.27"
<b>Specification</b>	with plate
Technical data	
<b>Current</b>	16 A
<b>Voltage</b>	500 V
<b>Rated impulse withstand voltage</b>	6 kV
<b>Pollution degree</b>	3
<b>Rated voltage according to UL/CSA</b>	600 V
<b>Wire cross-section</b>	0,50 mm <sup>2</sup> - 4,00 mm <sup>2</sup>
<b>AWG size</b>	20 - 12
<b>Contact type</b>	turned silver plated
<b>IP degree of protection</b>	IP20 without enclosure, IP65/IP66/IP68/IP69 with enclosure
Further technical details	
<b>Characteristics according to EN 61984</b>	16A 500V 6kV 3; 16A 400/690V 6kV 2
<b>Mating cycles</b>	≥ 500
<b>Insulation resistance</b>	≥ 10 GΩ
<b>Contact resistance</b>	≤ 1 mΩ
<b>Weight</b>	82,00 g
<b>Operating temperature range (min, max)</b>	-40 °C ... +125 °C
<b>Conductors stripping length</b>	7 mm
<b>UL 94 flammability rating</b>	V-0
<b>Torque for main contact</b>	M3: 0,5 Nm; 4,4 lb.in (Ph0 or 0,8 x 4 mm)

Material properties	
<b>Main material</b>	Polycarbonate (PC)
<b>Other materials</b>	Contacts: copper alloy
<b>Colour</b>	RAL 7032 grey
<b>RoHs conformity</b>	Compliant with exemption 6(c): copper alloy containing up to 4% lead by weight
<b>China RoHs - EFUP</b>	50
<b>REACH SVHC substances</b>	Yes Lead
Approvals / Standards	
<b>Reference standard</b>	EN 61984:2009-06
<b>Certifications</b>	CSA, CQC, DNV-GL, BV, EAC
<b>UL</b>	PVVA2
<b>cUL</b>	PVVA8
General ordering information	
<b>EAN13 code</b>	8015747033060
<b>ETIM 7.0</b>	EC000438
Packaging Information	
<b>Packaging length</b>	230,00 mm
<b>Packaging height</b>	110,00 mm
<b>Packaging width</b>	180,00 mm
<b>Packaging weight</b>	2,79 kg
<b>Packaging volume</b>	4,55 dm <sup>3</sup>
<b>Packaging description</b>	Carton box
<b>Packaging quantity</b>	30 Pcs
<b>Packaging EAN code</b>	8015747033077
<b>Sub-packaging length</b>	87,00 mm
<b>Sub-packaging height</b>	36,00 mm
<b>Sub-packaging width</b>	180,00 mm
<b>Sub-packaging weight</b>	0,47 kg
<b>Sub-packaging volume</b>	0,56 dm <sup>3</sup>
<b>Sub-packaging description</b>	Carton tray
<b>Sub-packaging quantity</b>	5 Pcs
<b>Sub-packaging EAN barcode</b>	8015747033084

Part number

# CNEM 16 T



Catalogue drawings

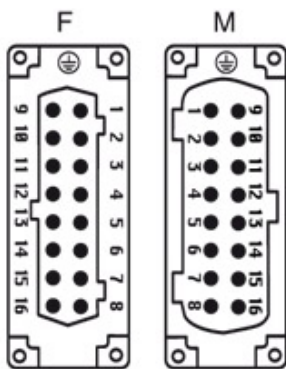
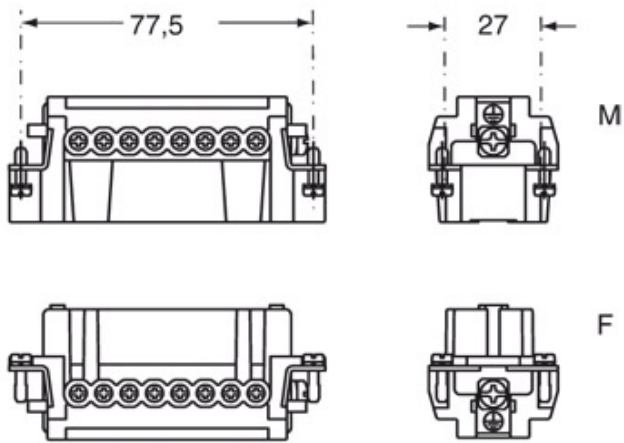

Catalogue drawings

